

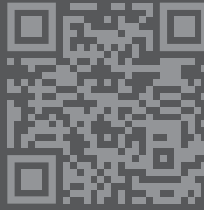

**Sustainable  
Defensible Space**

**Wildland  
Urban Inter  
face Wildfire  
Resilience  
Homeowner  
Handbook**



In 2019, the Resource Conservation District of the Santa Monica Mountains (RCD) received funding from the California Department of Forestry and Fire Protection (CALFIRE) through the California Climate Investments Program to create [defensiblespace.org](https://defensiblespace.org), a platform to improve the fire safety and habitat quality of the defensible space of homes in the Wildland Urban Interface (WUI).

The Technical Advisory Committee for [defensiblespace.org](https://defensiblespace.org) included representatives from National Park Service, Los Angeles County Fire Department, Los Angeles County Department of Regional Planning, Ventura County Fire Department, California State Parks, Santa Monica Mountains Conservancy, Mountains Recreation & Conservation Authority, Mountains Restoration Trust, U.S. Geological Survey, University of California, California Native Plant Society, North Topanga Canyon Fire Safe Council, Theodore Payne Foundation, and TreePeople. Design partners included RIOS and Persechini & Co.

The Guidance for Sustainable Defensible Space Landscaping in the Santa Monica Mountains National Recreation Area (SMMNRA) and Southern California Program is part of California Climate Investments, a statewide program that puts billions of Cap-and-Trade dollars to work reducing greenhouse gas emissions, strengthening the economy, and improving public health and the environment — particularly in disadvantaged communities. For more information, visit the California Climate Investments website at: [caclimateinvestments.ca.gov](https://caclimateinvestments.ca.gov)

# Sustainable Defensible Space



## Table of Content

### Introduction

- 1 The Role of Sustainable Defensible Space

### House: Start with Your Home

- 4 Roofing Materials & Maintenance
- 8 Open-Eave Design
- 11 Rain Gutters & Leaf-Guards
- 14 Vents & Ember Intrusion
- 17 Windows & Skylights
- 20 Doors & Garages
- 23 Walls, Sidings, & Coatings
- 26 Fences
- 29 Decks & Ember Ignition

### Firewise Landscape

- 31 Zone 0: The Ember-Resistant Zone (ERZ)
- 35 Zone 1: The Home Protection Zone
- 40 Zone 2: The Reduced Fuel / Thinning Zone
- 45 The Surrounding Wildland
- 49 Planning Around Seasons: Maintenance & Upkeep

### Plants

- 57 What Is a “Fire-Resistant” Plant?
- 61 The Habitat Value of a Native Garden
- 66 Fire & Invasive Species

### Location

- 73 No Two Places Alike: Learn About Your Location

### Community

- 75 Organize with Your Neighbors: Community Planning
- 79 What to Do Before, During, & After a Fire
- 83 Make Your “Wildfire Action Plan” Today!

### Tools for House & Landscape

- 87 Self-Assessment Checklist

### More

- 92 FAQs & Resources

# The Role of Sustainable Defensible Space

1

Visit our site for more info:

[DefensibleSpace.org](https://DefensibleSpace.org)

# Intro

Sustainable Defensible Space is the area around the home extending up to 100 feet. The condition of this space is critical, not only to increase the resistance of structures to wildfire loss and safeguard firefighters, but also to improve conservation value and protect California's natural heritage. The landscaping surrounding a home provides the greatest opportunity for improved habitat conservation, biodiversity support, and slope stability, as well as increased carbon storage and water conservation.

## Understanding the Local Environment & Wildfire Risk

We designed an interactive map that you can find on our website, for residents to learn about the individual qualities of their location: [DefensibleSpace.org/location](https://DefensibleSpace.org/location). It shows how a property fits within the local habitat types, for example, oak woodland, coastal sage scrub, or chaparral. You can explore previous fires in an area, as well as the jurisdiction and protection plans established in that community. We hope this information helps residents like you understand their particular location, and how the decisions they make on their own property, in conjunction with decisions made by others in their community, can influence our collective vulnerability to wildfire.

The Community section examines the outermost part of the defensible space zone, extending into neighboring properties. To maximize the benefits of home fire-wise landscaping, it is important for residents to work collaboratively with neighbors to understand the nature of shared risks and how to mitigate them.

The key to protecting homes and properties from fire in the WUI starts with the home. The Los Angeles County Fire Department estimates that embers cause the ignition of more than half of the homes that burn in wildfires. Fortifying or retrofitting a home can be the best defense against ember intrusion. Whether building a new home or retrofitting an existing one, our website details a number of things you can do.

2



## Why Is Defensible Space Important to You?

Embers from wildland fires can enter the house through many different routes, but exterior vegetation is not the only fuel providing those embers. Wildland fires can also be spread from structure to structure, or from structure to wildland vegetation. The most important place to begin preparing defensible space is with your home. Fortifying or retrofitting your home can be your best defense against ember intrusion. The key to protecting your property from fire is to start from the house out.

In addition, practicing appropriate landscape fuel management (ornamental or native), land maintenance, and thoughtfully selecting plants for a home's defensible space zone are the next significant actions homeowners can take. The zone that most contributes to structure survival is within the first sixty feet from the home. We have a section on the website that address home landscape management, providing clear guidance with resources that are consistent statewide.

3

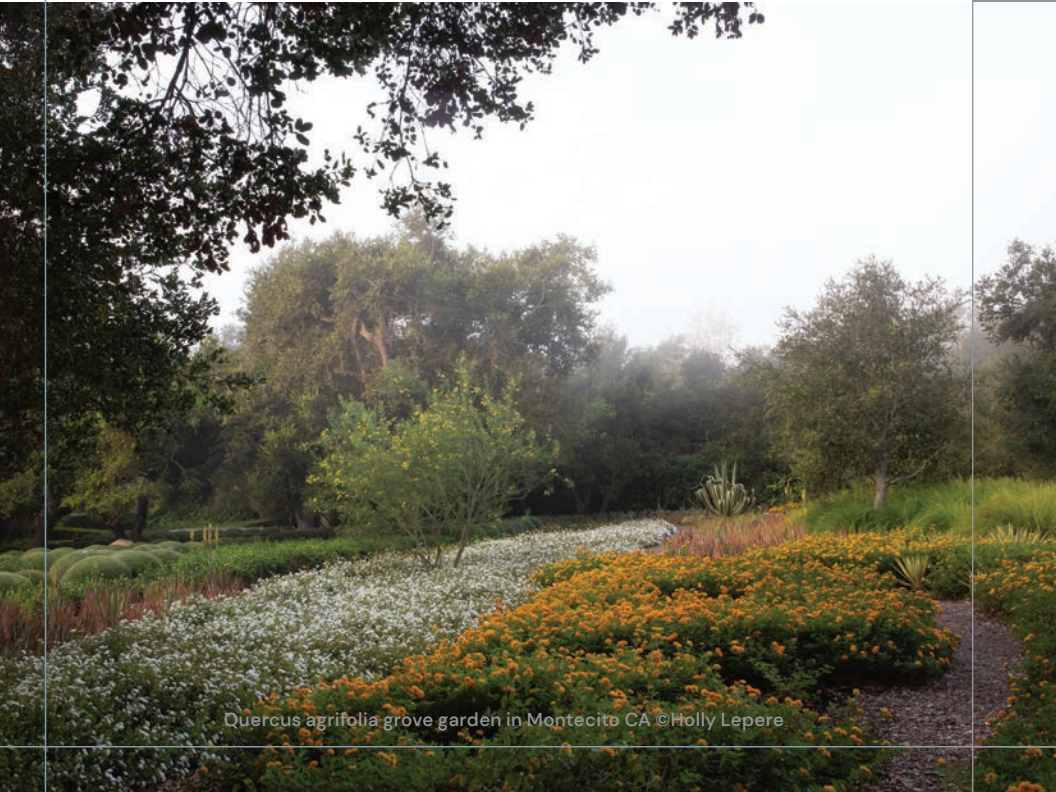

Quercus agrifolia grove garden in Montecito CA ©Holly Lepere

## Roofing Materials & Maintenance

4

Visit our site for more info:  
[Defensiblespace.org/house](https://Defensiblespace.org/house)

# House

The roof is the most vulnerable component of your home! During a wildfire it must be able to resist wind-blown embers and other wildfire exposures. Complex roofs, where the roof meets vertical walls and/or includes dormers, present additional vulnerabilities. Replacing a roof is a major project, but it can yield major benefits. Evaluating the vulnerability of the roof should be a top priority when considering a new home or remodeling an existing property. Proper roof maintenance is critical to reducing the ignition risk of your home!

### Roof Covering & Assemblies: Class A Roof Is the Best for Your Home

Roof covering fire ratings are Class A, B, C, or unrated; with **Class A providing the best performance**. Common Class A roof coverings include asphalt fiberglass composition shingles, concrete and flat/barrel-shaped tiles. A roof can achieve a Class A rating on its own (stand-alone Class A) or when combined with other fire-resistant elements (assembly-rated Class A). Some materials can have a “by assembly” Class A fire rating. This means that additional materials must be used between the roof covering and sheathing to attain that rating.

**Common stand-alone Class A roof coverings** include: clay tiles, slate, asphalt fiberglass composition shingles, concrete and flat/barrel-shaped tiles, some metal roofing materials.

**Common assembly-rated Class A roof coverings** include: aluminum roofs (because of low melting point), pressure-impregnated fire-retardant treated shake or shingle covering (not allowed in many jurisdictions), some recycled rubber and/or plastic composite materials.

### Block Gaps Between Covering & Sheathing

Some roof types are subject to gaps between roof covering and sheathing which typically occur at the ridge and edge of roofs.

These openings can allow birds and rodents to build nests with materials that are easily ignited by embers. Flames from

this type of ignited debris can spread to the structural support members, bypassing the protection offered by a Class A rated roof covering. Plugging these openings between the roof covering and the roof deck, is commonly called “bird-stopping.” Regularly inspect and maintain these areas.

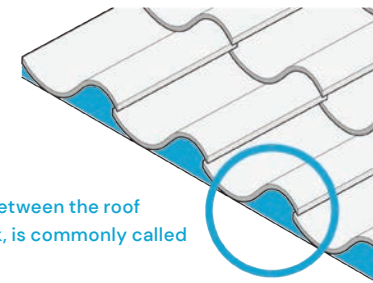

Plugging these openings between the roof covering and the roof deck, is commonly called “bird-stopping”.

### Why Should You Cover the Chimney with Screens

Windborne embers and firebrands can enter your home through your chimney or stovepipe outlet if it is not protected and maintained correctly. Vegetative debris can also accumulate on the roof adjacent to the chimney chase. This is another roof-to-wall connection that can be vulnerable to ignition by embers.

To protect your chimney you should:

- Install metal-flashing at roof-to-siding intersection to reduce the vulnerability of the chimney chase.
- Cover your chimney and stovepipe outlets with non-combustible corrosion-resistant metal mesh screen (spark arrestor), with 3/8-inch to 1/2-inch openings. Do not use fiberglass or plastic mesh as they can melt or burn.
- Remove tree branches within 10 feet of any chimney outlet.

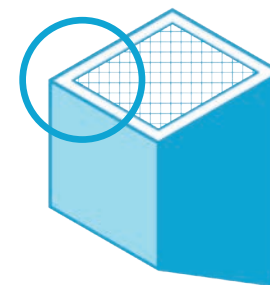

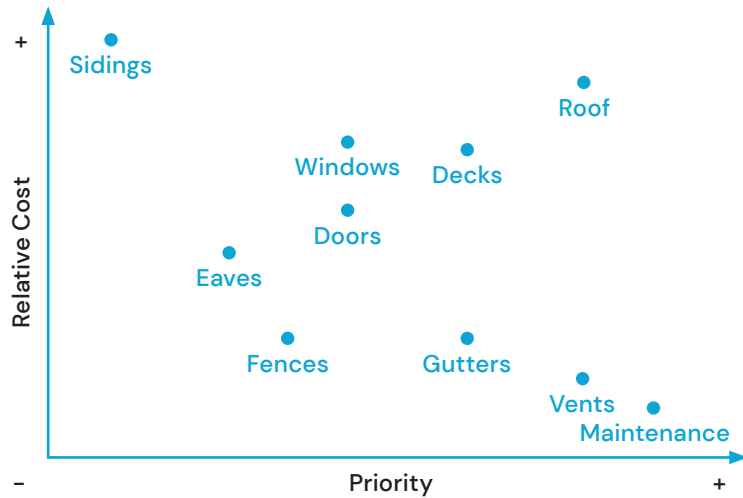

Relative cost and priority level of home hardening features for fire-resistance.  
 ©Resource Conservation District of the Santa Monica Mountains house

The above graphic is intended to aid homeowners in prioritizing home hardening decisions.

- Relative Cost: indicates the relative cost of upgrading the listed features to ember-resistant materials and design.
- Priority Level: indicated the features most vulnerable to wildfires and embers. Keep in mind each situation is unique and may change your priority level.

# Open-Eave Design

Visit our site for more info:  
[Defensiblespace.org/house](http://Defensiblespace.org/house)

# House

The under-eave area is an exposed and vulnerable feature to windborne embers, direct flames, and radiant heat. There are a few easy steps that can help reduce the risk of ignition in this area by using noncombustible materials and retrofitting open eaves.

### What Are Eaves, Overhangs, and Soffits?

1. **Eaves** are located at the down-slope edge of a sloped roof and serve as the transition between the roof and fascia/wall. An eave typically has a metal edge flashing and gutter that are attached to a wood fascia trim board.
2. **Overhangs** are extensions of the roof beyond the exterior wall. An overhang protects the upper portion of the wall from rainfall, and it also shades the windows under it from sunlight.
3. A **soffit** encloses the underside of sloped or flat-roof overhangs. Soffits are commonly constructed from fiber-cement panels, metal panels, stucco, vinyl panels, or wood sheathing. Metal panels, untreated wood panels, and vinyl panels are vulnerable to damage from wildfires. Metal panels conduct heat and can distort and allow passage of embers and hot gases. Untreated wood panels can ignite, and vinyl panels can melt and fall away.

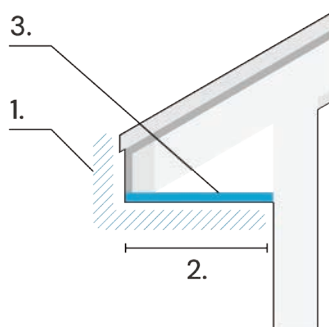

### How to Retrofit Your Eaves?

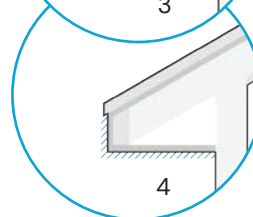
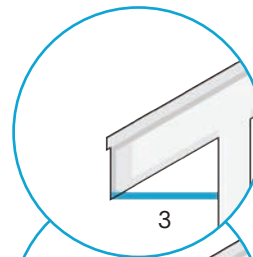
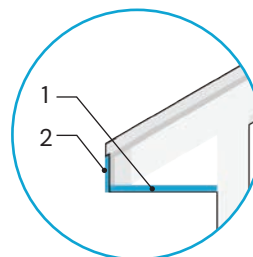

1. Evaluate the fire-resistance of existing soffits and replace soffits that are not fire-resistant.
2. If the fascia is combustible, cover the fascia with a noncombustible or fire-resistant material (e.g., fire-retardant-treated lumber, fiber-cement board).
3. If you have open eaves, install a soffit with a minimum 1-hour fire-resistance rating.
4. Install exterior 5/8-inch fire-resistant gypsum board between the existing and new soffit materials for enhanced fire resistance.
5. For open eaves, use a sealant (e.g., caulking) to cover gaps between blocking and joists.
6. Install fire-resistant or non-combustible soffit. Make sure to maintain existing vents and upgrade for ember resistance (see "Vents & Ember Intrusion", page 14).
7. Remove vegetation and combustible items from under the eaves and overhangs (see "Zone 0: The Ember-Resistant Zone", page 31).

# Rain Gutters & Leaf-Guards

Visit our site for more info:  
[DefensibleSpace.org/house](https://DefensibleSpace.org/house)

# House

Wind-blown debris (including leaves and pine needles from nearby and overhanging trees) can be ignited by embers. Once ignited, flames can extend to the edge of the roof and adjacent siding. Upgrade your gutters to prevent these debris from accumulating on your roof and in your gutters.

## Installing Leaf-Guards

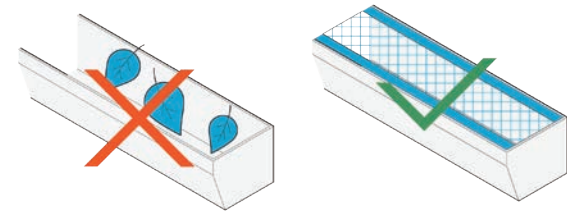

Install noncombustible leaf guards over gutters to prevent the accumulation of combustible debris. Types of leaf guards include metal-mesh screens and metal hoods that fit into the gutter.

## Installing Drip Edge

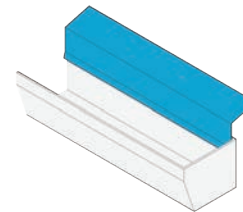

Some metal gutters have an integral flashing piece that serves the function on of a stand-alone drip edge. If a drip edge is not present, install one. The drip edge will serve two purposes:

- It will help protect the roof edge (sheathing and fascia) from a flaming exposure that could occur if debris is ignited by wind-blown embers, and
- It will minimize the entry of embers into a soffited-eave construction by blocking the small gap that can exist between the edge of the roof sheathing and the top of the fascia.

### Using Non-Combustible Materials



Use gutters and downspouts constructed of noncombustible materials such as galvanized steel, copper, and aluminum. Metal hood leaf guards are recommended because they do not melt and are relatively effective in keeping debris out of gutters.

## Vents & Ember Intrusion

Visit our site for more info:  
[Defensiblespace.org/house](https://Defensiblespace.org/house)

# House

Roof vents are important features for air circulation and removing excess moisture in the attic. However, they are highly vulnerable to flame entry and ember attacks. Embers and hot gases from nearby vegetation or buildings can be blown or pulled into the openings and enter attic spaces, crawlspaces, ductwork, potentially leading to ignition from the inside of the building.

### Locating Vents on Your Home

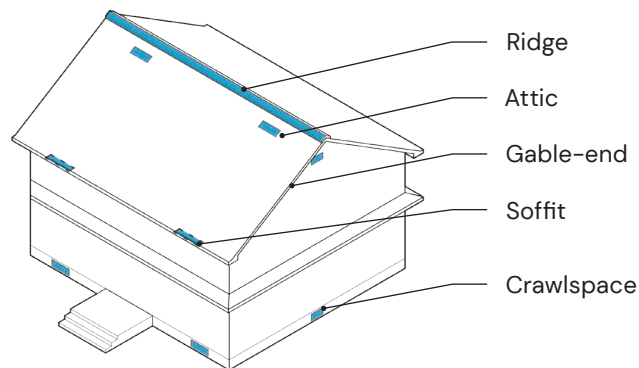

- Attic and ventilated cathedral ceilings vents.
- Crawlspaces vents.
- Heating, ventilation, and air conditioning (HVAC) systems.

### How to Reduce the Risk for Ember Intrusion?

- Use **non-combustible materials** for all vents and vent flashing (metal preferred).
- Install corrosive-resistant, **metal mesh screens with a maximum opening of 1/8 inch (3.2 mm)** at all vent openings.
- Attic and soffit vents should be baffled to prevent ember intrusion. A metal mesh only reduces the risk of intrusion.

- Install shutters over gable-end vents, soffit vents, crawlspace vents, and wall louvers. If the existing wall or soffit is combustible, shutters may not be effective. In this case, consider upgrading the walls or soffits with non-combustible material.

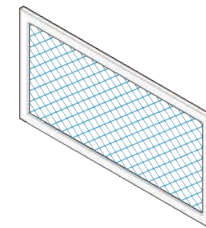



# Windows & Skylights

Visit our site for more info:  
[DefensibleSpace.org/house](https://DefensibleSpace.org/house)

# House

Windows, sliding glass doors, and skylights are key structure components to prevent ignition of the interior of your home. Combustible framing materials can ignite or deform, and the glass can crack and fall out due to thermal stress from direct flame contact or radiant heat.

## Recommended Materials

- **Tempered glass** is 3 to 4 times more resistant to heat and flames than laminated or annealed glass. The resistance of tempered glass can be enhanced with a low-e coating or a proprietary reflective coating.
- **Glass with a low-e coating** provides a higher level of resistance to radiant heat than other types of glazing because the coating reflects radiant heat, reducing the probability that the heat will be able to enter the building.
- **Proprietary fiberglass-reinforced translucent glazing** is a product available for skylights and windows. The skylight material has a Class A rating.
- **Insulated glazing unit (IGU)** consists of two or three panes of glass that are separated by a sealed air space. Double-paned annealed units last about 10 minutes in a wildfire, twice as long as single-paned windows.
- Frames should be constructed only of **metal or metal-clad wood**. Wooden and plastic frames should not be used. Plastic-clad fiberglass should not be used either, as it will fail in direct flame contact.

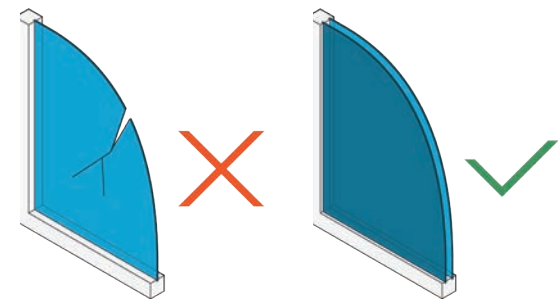



## Exterior Window Shutters Can Help

Exterior window shutters can provide protection for windows and sliding glass doors in a wildfire. Solid metal shutters are unlikely to ignite or melt and are therefore recommended over wooden or plastic shutters.

## Skylights

1. **Low-Slope Roof:** Vegetative debris can accumulate more on a low-slope roof, increasing the risk for a flat glass skylight to break as the typical flame temperature from wind-blown ember-ignited debris is high enough to break tempered glass typically used for the outer pane. For this reason, dome skylights are preferred on low-slope roofs.
2. **Steep-Slope Roof:** Flat skylights are less vulnerable on a steep-slope roof because vegetative debris is less likely to accumulate. Skylights on steep-slope roofs are however still vulnerable to extended radiant heat exposure from nearby vegetation and combustible materials.

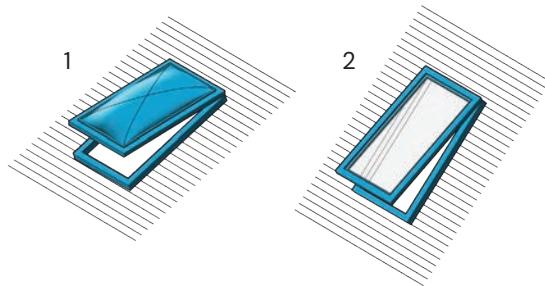

# Doors & Garages

Visit our site for more info:  
[Defensiblespace.org/house](https://Defensiblespace.org/house)

# House

The design and construction of exterior doors, including garage doors, on buildings in wildfire zones is critical to preventing ignition from ember intrusion or radiant heat. Exterior doors are subject to the same types of exposure as exterior walls but are usually much thinner and less resistant, making them an important component in your home hardening plan.

### Choosing Exterior Doors

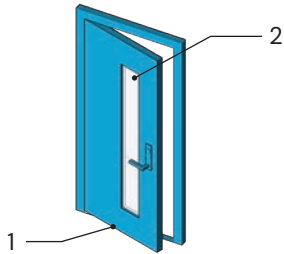

1. Install a **fire-rated door and frame**. Doors with a solid, noncombustible mineral core are classified as fire-rated doors. Exterior fire-rated doors are available with a rating of 1½ hour or 3/4 hour.
2. For door glass vision panels and glass sliding doors, follow recommendations in Windows & Skylights.

### Considerations for Garage doors

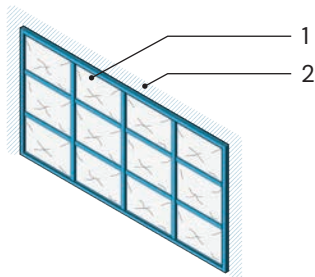

1. Install insulated, metal garage doors.
2. Install **weatherstripping** that has been tested in accordance with UL Standard 10C around the entire garage door.

For exterior trim that covers the opening between the door frame and exterior wall, install noncombustible or fire-resistant material such as fire-retardant-treated wood or fiber-cement board.

### Weatherstripping

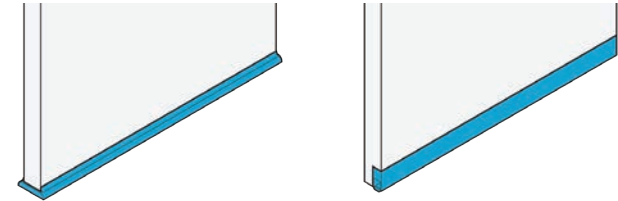

Install adjustable weatherstripping on the interior side of the door frame and specify and install an automatic door bottom or threshold weatherstripping. The weatherstripping and door bottom should be tested in accordance with UL Standard 10C. Weatherstripping is relatively inexpensive.

## Walls, Sidings, and Coatings

23

# House

Visit our site for more info:

[DefensibleSpace.org/house](https://DefensibleSpace.org/house)

Exterior walls are susceptible to windborne embers, conductive heat, and radiant heat. Flames and heat can ignite combustible wall coverings such as solid wood and wood composite. Vinyl and plastic products can deform and slough off when exposed to flame and heat. When exterior walls ignite, the fire can spread to other components of the building such as the roof, soffit, windows, and doors, resulting in substantial damage to or total loss of the building. Windborne embers and firebrands are common sources of ignition and can become trapped in cracks in walls, window openings, and door trim boards.

### Considerations for Materials

- **Recommended materials:** Concrete, fiber-cement panels, traditional three-coat stucco, masonry, metal (no aluminum), pressure impregnated fire-retardant treated wood.
- **Non-recommended materials:** Non pressure impregnated fire-retardant treated wood, vinyl, aluminum (susceptible to warping), exterior insulation finish systems (EIFS)

If you have a combustible siding and are unable to replace it in totality, target smaller areas that are vulnerable such as the 6-inch area at the base of the siding and the roof-to-wall area. Creating a 6-inch noncombustible area at the base of the siding will minimize the chance that the siding will ignite from embers at the ground level or direct flame contact.

### Intumescent Paints Are 'Not' Effective in Exterior

Intumescent coatings, often referred to as intumescent paints, are used in buildings as a passive fire resistance measure. Usually, they have been developed for interior use and are sometimes suggested for use in exterior applications, either applied as a primer or top-coat, on products such as siding.

24

While these products may work well in interior applications, **they tend to lose effectiveness when used in exterior locations**. The use of coatings as fire-retardants should be avoided in exterior exposures until adequate information regarding performance after weathering has been demonstrated.

## Fences

Visit our site for more info:  
[Defensiblespace.org/house](https://Defensiblespace.org/house)

# House

Landscape fencing and walls attached to or near buildings in wildfire zones can represent a high ignition risk by spreading flames or radiant heat from one building to another. The common wooden post-and-board fence can become fuel for a wildfire, especially when the fence is old and weather-beaten. It can also collect embers and firebrands in a wildfire and act as a horizontal ladder fuel by allowing the fire to travel along the fence. Masonry, concrete, stone, metal, and hardwood landscape fences and walls are effective ignition-resistant materials.

### Picking Common Fire Resisting Materials for Your Landscape Fencing

- **Wood:** Fences that are constructed of wood or have wooden components are combustible and therefore provide no fire resistance. A wood frame with steel mesh infill is an option that would minimize the possibility for an ember ignition; however, if vegetation is allowed to grow on the mesh infill, this advantage will be negated.
- **Plastic:** Plastic fences are more fire-resistant, more durable, and often stronger than wooden fences, but plastic fences can melt in a wildfire from temperatures that are below the maximum a wildfire can generate.
- **Metal:** Metal fences are more fire-resistant than plastic fences. Wire fences such as barbed wire, hog wire, and chain link have little or no effect on fire passage. However, if combustible materials have accumulated in or around the fence, it can act as a horizontal ladder fuel by allowing the fire to travel along the fence.
- **Concrete, Stone, or Masonry:** Concrete, stone, and masonry fences as well as walls are noncombustible and can act as a barrier to a wildfire by deflecting flames away from a building.

### How to Reduce the Vulnerability of Your Fences?

- Avoid attaching fences and walls constructed of combustible materials to a building. For fences and walls that are attached to a building, ensure that all combustible components are **at least 5 feet from the building** to prevent heat and flames. A common technique is to use a metal gate with one side attached to the combustible fence and the other to the building.
- A fence design that allows for **greater air flow**, such as a **single panel** lattice fence, is better than a fence with lattice applied to both sides of the support posts because it is harder for wind-blown embers to accumulate at the horizontal to vertical intersection. For this reason, privacy fences with all planks on one side are the most vulnerable to ignition.

## Decks & Ember Ignition

29

Visit our site for more info:  
[DefensibleSpace.org/house](https://DefensibleSpace.org/house)

# House

Decks are important features because they are usually attached to a home and are next to a window or sliding glass access door. Consider the construction material used to build the deck, patio or porch, along with the furniture and other items stored beneath it. This area is part of your defensible space so you should also consider the vegetation leading up to the deck.

### Picking Decking Materials

Most commercially available deck boards are combustible. These include redwood, cedar and tropical hardwoods, such as ipe, and all plastic composite lumber decking products.

Sometimes there is a misunderstanding regarding the combustibility of plastic and wood-plastic composite decking products—these decking products are also combustible. Pressure impregnated fire retardant treated (FRT) wood deck boards are less vulnerable to flames and embers.

If your deck is not a fire-resistant deck and you want to mitigate your risk, consider removing and replacing deck boards with noncombustible material within a minimum of 5 feet of the house. Be careful to match the deck board thickness and select deck boards that comply with the California Building Code requirements.

### Recommended Spacing for Your Decks

Using proper spacing, your deck can be designed to minimize exposure to embers:

- Increase the **gap between deck boards** from 1/8 inch to 1/4 inch.
- Increase **joist spacing** from 16 inches to 24 inches. Apply a foil-faced self-adhering adhesive flashing tape (foil-faced bitumen tape) on the top of each joist. Foil tape should extend down each side of the joist 2-3 inches.

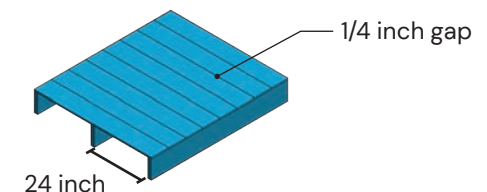

30

# Zone 0: The Ember-Resistant Zone (ERZ)

The size of the zones shown in the diagrams on the following pages are supported by research into home losses in wildfires, and are consistent with most local regulations at the time of publication. Based on this evidence and current CalFire standards, we show a maximum distance for native vegetation modification of 100' from the house. However, the type of vegetation, terrain, and local regulations may require additional thinning beyond 100'. The Los Angeles County Fire Department may require up to 200' of defensible space. Contact your local Fire Department for specific requirements.

Native vegetation is often protected by regulations, so do not remove previously unmodified habitat without first contacting your local County planning department for specific limitations and processes.

If you are neighboring a State Park or Protected Area, you may apply for a Boundary Vegetation Modification Right of Entry Permit (BVMROE) to address your desired defensible space. An approved permit allows homeowners or their contractor access to State Park land to trim vegetation within 130 feet of the closest habitable structure. To learn more about obtaining a State Parks BVMROE permit to complete defensible space for your home, contact California State Parks at [info@parks.ca.gov](mailto:info@parks.ca.gov)

Visit our site for more info:  
[DefensibleSpace.org/landscape](https://DefensibleSpace.org/landscape)

# Landscape

We have identified three zones for sustainable defensible space around the home. The specific needs for zones 0, 1 and 2 are described in the landscape chapter, as well as management recommendations for the surrounding wildland.

## What Is Zone 0: The Ember-Resistant Zone (ERZ)



The Ember-Resistant Zone is the first 5 feet around your home, including the structure itself. The objective in this zone is to avoid ignitions from windblown embers landing on or near the direct surroundings of the house and starting a fire. **Ember ignitions are responsible for the majority of homes lost or damaged in wildfires.** In the Ember-resistant Zone, all home building materials, vegetation, equipment, outdoor furniture, toys or anything else that could be ignited by embers must be removed or replaced. **Research from the Insurance Institute for Business and Home Safety (IBHS) shows that the first 0 to 5 feet around the house has the greatest impact on reducing the risk of losing a home to wildfire.**

**Zone 0 is a recommended "lean" or no planting zone.** Do not use combustible landscape mulch or wood chips and prefer clear soil, gravel, pavers or concrete. The guidance provided in the following pages for this zone is subject to change based on the regulations that will be developed by the State Board of Forestry and Fire Protection. Regulations are under development and are scheduled to take effect January 1, 2023, for all new buildings and January 1, 2024, for all existing buildings.

The size of the zones shown in the diagrams on the following pages are supported by research into home losses in wildfires and are consistent with most local regulations at the time of publication. Based on this evidence and current CalFire standards, we show a maximum distance for native vegetation modification of 100

feet from the house. However, the type of vegetation, terrain, and local regulations may require additional thinning beyond 100 feet.

**Contact your local Fire Department for specific requirements.**

**Native vegetation is often protected by regulations.**

Do not remove previously unmodified habitat without first contacting your local County planning department for specific limitations and processes.

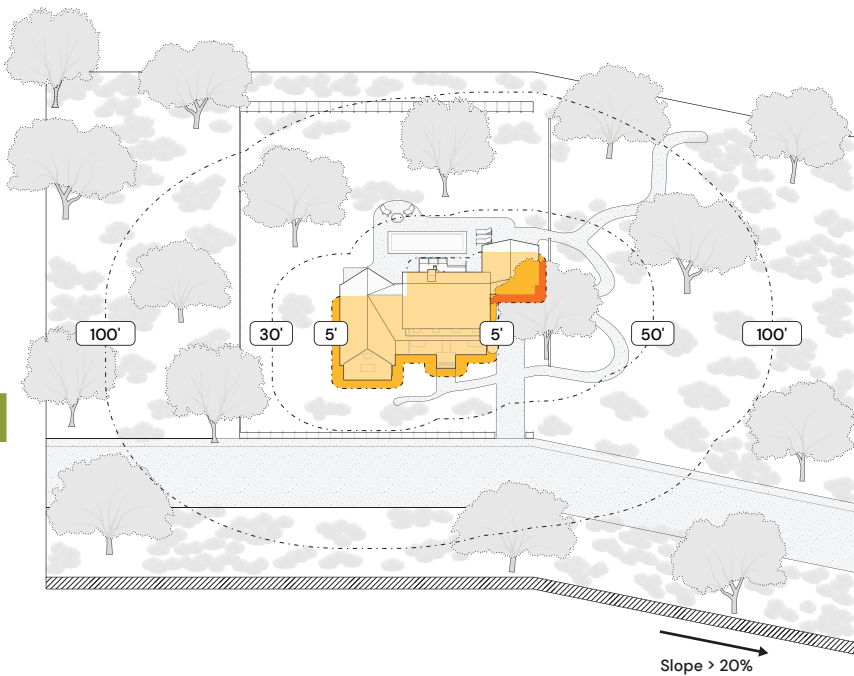

### Recommendations for Zone 0

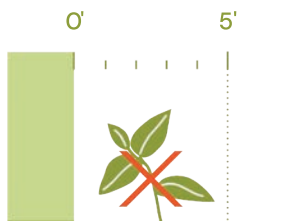

- **This should be a "lean" or no planting zone.** Guidance subject to change based on State regulations currently under development.

- Keep surrounding area of your structures clear of combustible materials. No firewood.
- Install hard surfaces, such as concrete walkways, or use non-combustible mulch products such as rocks and gravel.
- Maintain a 5-foot zone free of dead plant materials.
- Avoid vines and climbing plants in this zone, including on fences, decks, patio and shade structures.
- Include the footprint of any attached structure, such as a deck, within the Ember-Resistant Zone.
- Maintain a 5-foot ember-resistant zone around sheds, detached garages, and other accessory dwelling units.
- Keep 6 inches of non-combustibility above ground at the base of your walls to prevent ignition of the siding. Hardscaping is strongly recommended around the base of structures.
- For lean planting, prefer well spaced non-woody small herbaceous or succulent plants. Keep plants lean, green, and well irrigated year-long.

### Mulch for Zone 0: What You Should Know



- Do not use organic mulch within the ember-resistant zone.
- Only use inorganic mulch such as rocks and gravel.
- Do not use rubber or plastic-based mulch. Rubber mulch can produce remarkably high temperatures and flames when ignited. It ignites easily, and can burn intensely for a prolonged period.



## Zone 1: The Home Protection Zone

35

Visit our site for more info:

[DefensibleSpace.org/landscape](https://DefensibleSpace.org/landscape)

# Landscape

Yes, you can have both a beautiful native landscape and a firewise home through proper planning! Our website's recommendations for new and existing landscapes work in partnership with a seasonal maintenance checklist to help maintain a sustainable defensible space all year round.

### What Is Zone 1: The Home Protection Zone

The Home Protection Zone should be designed to create and maintain a landscape that, if ignited, will not transmit fire to the home. Depending upon the type of wildland vegetation in the area and the steepness of the slope, this zone should have an area at least 30 feet wide (50 feet for slopes above 20%) that is **lean, clean, and green**. Trees should be spaced to allow min 10' clearance to structure at full maturity.

The Home Protection Zone should be designed to promote fire-wise landscaping and water conservation. **It is a recommended minimum planting zone starting with low-density planting to medium-density as you move outward from the house.** The goal is to create a low-ignition landscape capable of slowing down fire spread. Plants that are green and lush give better protection. If regularly watered and pruned to remove dead or unhealthy material, these plants will be far less likely to carry fire to your home. While all plants will eventually burn, healthy ones with a high moisture content are more difficult to ignite.

**Defensible space** is the area between your home and an oncoming wildfire. **All vegetation, including native plants and ornamental plants, are potential fire fuel.** Firewise landscapes should also include hardscape, such as granite paths and stone walls. These can act as fire break — in between **islands of native vegetation** — and help to slow down or change the path of an approaching fire.

36

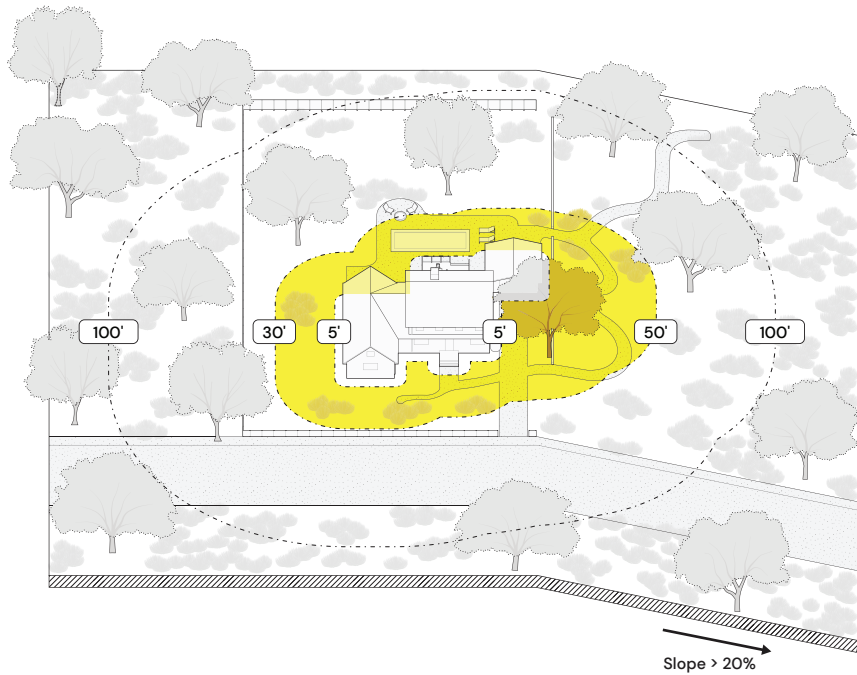

### Recommendations for Zone 1

- Plant primarily native species within Zone 1 and 2. Native plant species support local ecosystems and wildlife. More information about native plants on pages 61–65.
- Non-native plant species that are not invasive may be allowed, although we recommend using primarily native species. Remove invasive plants. Find a list of the common invasive plant species on pages 68–72.
- Ground covers and shrubs with occasional small tree are recommended for this zone.
- Plant trees that do not exhibit flammable characteristics. Find out more about what makes a plant flammable on pages 57–60.
- Create a drip irrigation system to promote water conservation and promote well maintained plants. More information online at [DefensibleSpace.org/plants](http://DefensibleSpace.org/plants).

### Mulch for Zone 1: What You Should Know

- Prefer **composted wood-chips** from tree trimmings and plant material, it screens off weeds when applied as a layer 2" to 4" thick, reduces evaporation from the soil surface, cuts watering needs and promotes soil microorganism activity.
- Do not use rubber or plastic based mulch. Rubber mulch produces remarkably high temperatures and flames when ignited. It ignites easily and burns intensely for a prolonged period.

### How Much Is Enough? Ensure Proper Spacing

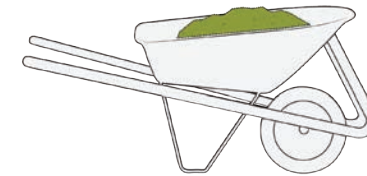

Make sure your shrubs and trees are trimmed and maintained to allow for **horizontal and vertical spacing** with your house and other plants or structures.

- If your tree is more than 18-feet high, remove all tree branches at least 6 feet off the ground.
- If your tree is less than 18-feet high, remove all tree branches within the first 1/3 of the tree height.

Additional vertical spacing may be required if shrubs or bushes are planted under the tree. Take a look at the diagram above on proper spacing to learn more.

Ideally, there should be at least 10 feet of horizontal spacing between the branches of other trees or structures such as decks, garages, sheds. Note that additional spacing may be required on steep slopes.

## Hardscape: Designing Against Fire

Take advantage of multiple hardscaping solutions to protect against fire by doing:

- Create **islands of vegetation** interrupted by non-flammable pathways, walls, or dry creek beds.
- Stabilize your slope with retaining walls or terracing. These structures can help **break up fire-generated winds** and stop embers from blowing along the ground.

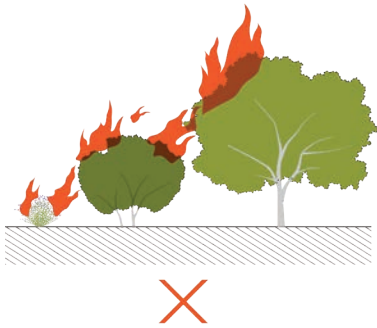

Avoid the fire ladder effect.

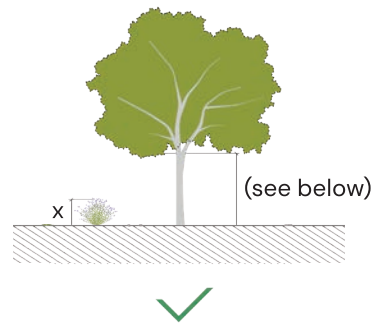

Eliminate ladder fuels by disrupting the vertical and horizontal continuity of plants. 6 feet or 3x height of shrub is the minimal vertical clearance.

## Zone 2: The Reduced Fuel / Thinning Zone

Visit our site for more info:

[Defensiblespace.org/landscape](https://defensiblespace.org/landscape)

# Landscape

## What Is Zone 2: The Reduced Fuel / Thinning Zone

The Reduced Fuel / Thinning Zone has a dual function. It serves as a **connection with the natural environment** promoting habitat restoration while eliminating continuous, dense vegetation, to decrease the energy and speed of the wildfire. The Reduced Fuel / Thinning Zone supports **habitat connectivity and wildfire discontinuity**. Do NOT remove vegetation down to bare soil, and do not destabilize hillsides by using heavy equipment; soil erosion and mudslides can result. Follow recommended spacing guidelines.

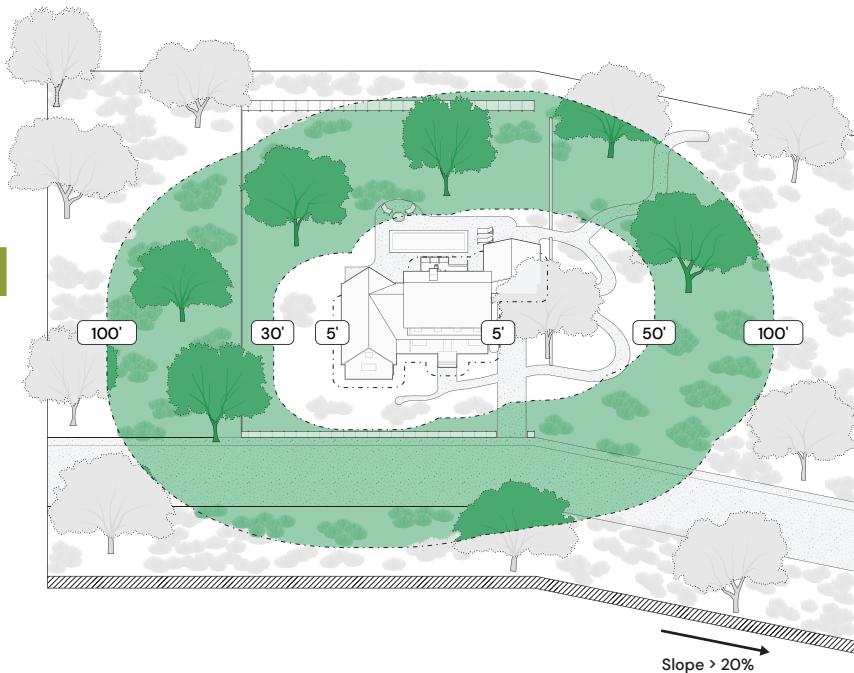

### Recommendations for Zone 2

- Plant primarily native species within Zone 1 and 2. Native plant species support local ecosystems and wildlife. More information about native plants is on pages 42–43 and 63–65.

- Remove invasive plants. Find a list of the common invasive plant species on pages 68–72.
- Only use native plant species as you move outwards, in order to support an **ecological transition with the surrounding wildland**.

### The Native “Soil Keepers”

If you live in the Wildland Urban Interface, there is a chance you are surrounded by hills or uneven terrain. To help avoid erosion and runoff on your property, **add native plants to stabilize the soils**, control erosion and reduce your future irrigation costs. Moist and cool months are ideal to start these “soil keepers”. Once established they will require little irrigation. A mixture of plants is best, with various root depths to hold up a slope. In addition, **a sprinkling of native seeds** will add to the immediate coverage of your slope. Check out the Native “Soil-Keepers” section under Native Plants on our website: [DefensibleSpace.org/plants](http://DefensibleSpace.org/plants)

Below are a few soil keepers to start with. Photos of the plants listed are courtesy of the Theodore Payne Foundation and Elisa Read Pappaterra.



#### Blue-Eyed Grass

*Sisyrinchium bellum*

Size: 1 feet (h) x 1 feet (w)

Delicate purple flowers, abundant from February to May, with grass-like leaves. A perennial, found naturally in grass meadows and other open places, re-seeds easily. A lovely addition to a dry border and does well in containers with well-draining soil. Likes sun to partial sun exposure. Foliage will die back in summer heat.



**California Fuschia**  
*Epilobium canum* or  
*Zauschneria californica*  
 Size: 2 feet (h) x 4 feet (w)

A very hardy native that can take a lot of abuse; commonly found in dry areas, rocky slopes and cliffs. Abundant, scarlet tubular flowers from July to November, popular with **humming-birds**. Likes sun to partial sun exposure, may be used as a ground cover.



**California Redbud**  
*Cercis occidentalis*  
 Size: 20 feet (h) x 15 feet (w)

An interesting plant year round, with beautiful pea-shaped magenta flowers on leafless stems in the spring, followed by interesting seedpods and heart-shaped bluegreen leaves. Deciduous, with yellow or red fall foliage on multi-branching stems. Prefers sun exposure. Excellent for dry, seldom watered banks.



**Twinberry Honeysuckle**  
*Lonicera involucrata*  
 Typical Size: 6 feet (h) x 6 feet (w)

Prefers moist areas and pruning will keep size under control. Dense foliage with unique orange-red flowers that produce berries, **attractive to birds**. Blooms in the spring, drops leaves in winter. Sun to partial shade exposure.

## Tips for Managing Terraces

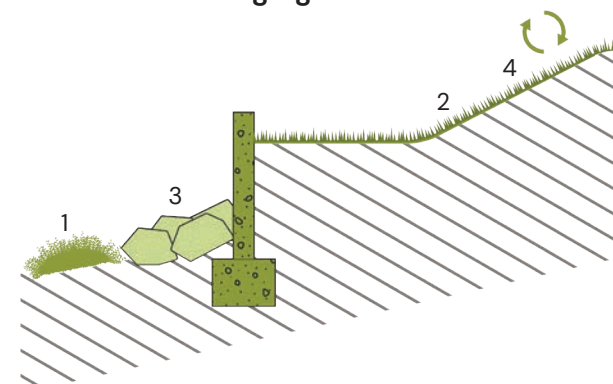

Terracing a slope can be great way to create a safer environment but terraces **need to be maintained** to avoid further erosion. The impermeable face of terracing structures can cause runoff and erosion as sheeting water undermines the base of the structure and increase topsoil loss. To avoid this problem, it is recommended to do the following:

1. Maintain a low-growing shrub at the base of the structure.



2. Maintain low-growing or ground-cover type of plants at the terraces with appropriate retaining wall drainage for rainfalls and groundwater management.
3. Install rip-rap at the base of the terrace to diffuse runoff and reduce topsoil loss.
4. Replace soil loss once a year by hauling it back up and compacting it.



## The Surrounding Wildland

45

Visit our site for more info:  
[DefensibleSpace.org/landscape](https://DefensibleSpace.org/landscape)

# Landscape

The wildland and native habitat is the reason why people choose to live here, surrounded by the beauty of a natural habitat that provides critical ecosystem services by supporting native vegetation and wildlife. However, continued habitat loss and fragmentation threaten the long-term existence of many native species and pose the greatest threats to biodiversity. These threats remain acute in Southern California and more specifically in the most rapidly expanding urban areas in the United States such as the Los Angeles basin, Orange County, and the greater San Diego area.

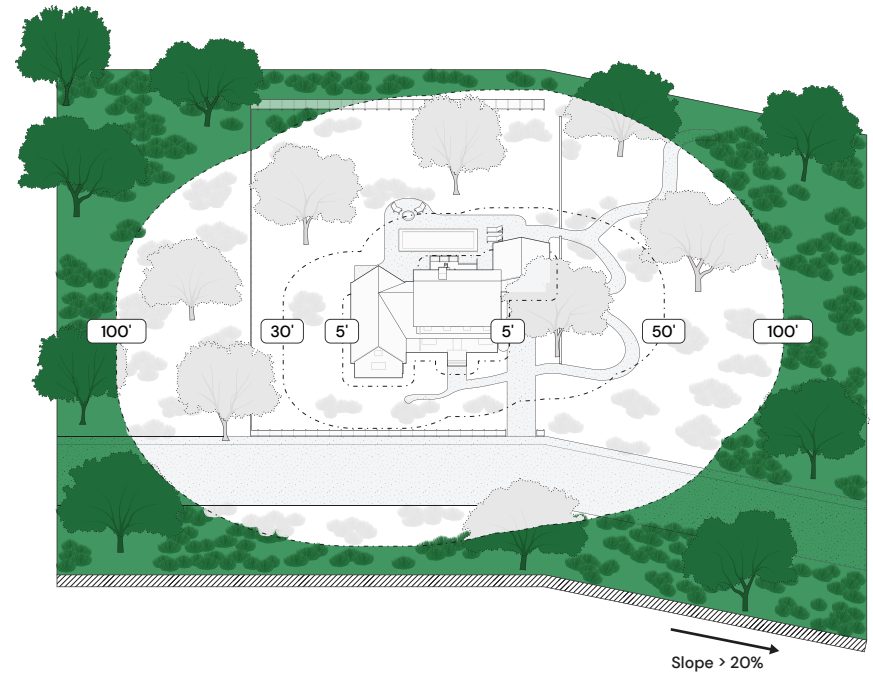

46

We emphasize here **two vegetation types that have been reduced and fragmented** following human-caused disturbance. Contributing factors include development, excessive vegetation clearance, and too-frequent wildfires, all of which may result in invasion of nonnative weeds that produce lighter, more flammable fuels. As intact habitat is lost, the numbers of rare, threatened, and endangered species rise. These species contribute to biodiversity

and **serve extremely important roles in natural ecosystems**. 149 plant and animal species that are rare, threatened, or endangered have the potential to occur in the Santa Monica Mountains.

When required by the Fire Department, this zone may require progressive thinning to lessen the spread of fire as it approaches the primary fuel modification zones. The amount of fuel reduction and removal should take into consideration the type and density of fuels, aspect, topography, weather patterns and fire history.

### Recommendations for the Wildland That Is Surrounding You

- Do not modify vegetation (except removing identified invasive species), **unless it is required by local Fire Departments**.
- Learn how to recognize native and invasive species within your environment. Resources are available on **PlantRight**, **California Native Plant Society**, **Theodore Payne Foundation**, and **Calscape**.
- Coordinate with your neighbors to create a community-wide fire-wise plan. For more information, you can visit **our website under the Community section**.
- Do not remove vegetation down to bare soil, and do not destabilize hillsides by using heavy equipment; soil erosion and mudslides can result.

### What You Should Know About the Native Ecosystem

**Chaparral** and **coastal sage scrub** are the predominant vegetation types in the Santa Monica Mountains. Together with the climate they grow in, they can produce extreme fire behavior, yet these plant communities are among **the most ecologically significant in Southern California**. They possess exceptional watershed values, including soil stabilization and groundwater recharge. The valuable viewsapes they create make the region a popular place to live and visit. They also provide crucial habitat to many declining species

of wildlife. These two vegetation types have been reduced and fragmented as a result of frequent and intense human-caused disturbance. Below photos are courtesy of Santa Monica Mountains National Recreation Area.

#### Chaparral

Dominant chaparral species are many, include small-leaved shrubs such as chamise (*Adenostoma fasciculatum*), and ceanothus (*Ceanothus spp*). This plant community is found in foothill areas and requires 20 years after being severely disturbed to establish and produce sufficient seed for successful reproduction.

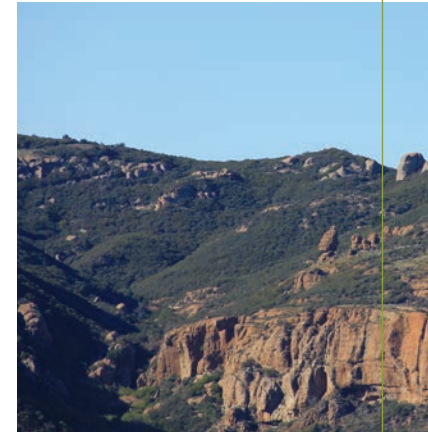

#### Coastal Sage Scrub

Coastal sage scrub includes soft, small shrubs under 3 feet tall that grow in areas below 2,500 feet elevation. This plant community includes semi-woody aromatic evergreen plants, such as **California sagebrush** (*Artemisia californica*), **California buckwheat** (*Eriogonum fasciculatum*), **black sage** (*Salvia mellifera*), and **white sage** (*Salvia apiana*).



This plant community is found on alluvial fans, bluffs, open range, and plains. Most wildlife species dependent on sage scrub require a minimum of 50 percent plant cover. **Coastal sage scrub takes up to 2 to 3 years to regrow after a fire** and a minimum of 10 years to recover following severe disturbance, such as complete removal.

# Planning Around Seasons: Maintenance & Upkeep

# Landscape

Visit our site for more info:  
[DefensibleSpace.org/landscape](https://DefensibleSpace.org/landscape)

The most important factor in creating a sustainable defensible space is maintenance. In this section we will explore key maintenance actions that should be performed seasonally to reduce the risk of ignition on your property and promote healthy vegetation.

## FALL

### A Good Time for New Plantings

Fall is a good time in Southern California to **begin new plantings**. The weather is beginning to cool down, yet temperatures are still warm enough to encourage germination. Ensure that your landscape is still fire-safe. **Clear your roof of fallen debris to prevent ignition from flying embers** in the event of a wildfire. **Maintaining your property is a year-round task**. With the start of our rainy season in mid-October, begins our Mediterranean climate's "green season", which is the best time to plant some new young plants, and sow some wildflower seeds.

#### Caring for Plants During Fall

1. Prevent fallen, dried leaves from building up to dangerous levels. Use a rake, not a leaf blower to clean them up.
2. Prepare for rain and erosion.
3. Reduce watering using smart controllers for an **irrigation based on weather forecasts** and the strength of the rainy season (usually November to March/April in Southern California).
4. Monitor water needs of newly installed plants. The **establishment phase is critical** and will ensure long-term health of your landscape.





### Pruning for Healthy Plants During Fall

- Evergreen herbaceous perennials and shrubs **can be pruned in the fall for rejuvenation.**
- Shaping is better done by pruning plants **right after they flower** unless fruits are desired for their wildlife or ornamental value.
- Semi-evergreen species (such as Matilija poppy, monkey-flowers, goldenrods, and sages) can be pruned as they slow down and enter a resting period, **usually in late summer to early winter.**

You can also go to our website for maintenance tips by species: [DefensibleSpace.org/landscape](https://DefensibleSpace.org/landscape)

## WINTER

### A Good Time for Caring for Your Soil

Winter in Southern California is defined by the arrival of **storms bringing rain at lower elevations**, and often snow over 5,000 feet. Winter is a good time to care for your soil — in burned areas, erosion can be a problem. In fuel management zones, the retention of deep-rooted vegetation during spring fire hazard reduction projects should stabilize slopes.

#### Caring for Plants During Winter

1. Many plants such as citrus, avocado and even some natives are susceptible to frost in the winter. **Plants killed by frost can become a fire hazard in the Wildland Urban Interface.** Help your plants survive the cold by preparing for frost in early winter (December). Move tender container plants to a protected area. For plants in the ground that are susceptible to frost, wrap trunks and branches with insulating material or cover with a blanket.
2. Apply **organic mulches starting 5 feet away from your home or structure** (no organic mulch should be used in

Zone 0). Apply mulch 2- 4 inches deep around our plants to help retain water, feed the soil and avoid invasive seeds from germinating. Mulch also allows the soil to soak up rain fall. **Use composted wood chips!**

### Pruning for Healthy Plants During Winter

- Because so many of our **California woody plants are dormant in summer** and do their growing when the rain kicks in, the deep of winter is usually the wrong time for pruning. Exceptions to that rule include pines.
- For pines, plan on making any needed structural cuts in December or January. Annual, finer pruning work on pines can be scheduled for October or November.
- Winter-deciduous species **should be pruned during their dormant period**, after leaf drop.

You can also go to our website for maintenance tips by species: [DefensibleSpace.org/landscape](https://DefensibleSpace.org/landscape)

## SPRING

### A Good Time to Check Your Irrigation System

**Early spring is a good time to give your irrigation system a check-up.** Water plants deeply and only as needed. This encourages deep roots and drought tolerance, and discourages weeds, overgrowth, and snails. Before you begin your spring garden tasks, be aware that most birds nest from February to August. **Make sure that fuel management activities do not disturb nests.** Look first before cutting.

#### Compost for Your Garden



If you haven't already, start composting green waste as part of your spring cleaning. Also, leaving grass clippings on your lawn as mulch provides nutrients to your soil, helps retain soil moisture, and keeps green waste out of **landfills**. For more information,

use the urls below to read these publications: [Compost in a Hurry \(anrcatalog.ucanr.edu/pdf/8037.pdf\)](http://anrcatalog.ucanr.edu/pdf/8037.pdf) and [Mowing Your Lawn and "Grasscycling" \(bit.ly/MowingYourLawnAndGrasscycling\)](http://bit.ly/MowingYourLawnAndGrasscycling).

### Pay Attention to Your Weeds

Spring is a critical time to pay attention to weeds that have sprouted in response to the winter rains. Check for the presence of any invasive species and remove them. Learn more about invasive species in our dedicated section on our website:

[DefensibleSpace.org/plants/#section-invasive](http://DefensibleSpace.org/plants/#section-invasive)

## SUMMER

### A Good Time to Plan for Fall

Peak summer is not the time for overzealous pruning or fertilizing, both of which can force the plant to put out new growth when it's least likely to survive. Late summer is a good time to begin planning for the fall planting season. Local botanical gardens or community colleges host design classes that will help you make the most of your garden.

#### Caring for Plants During Summer

1. Water appropriately to maintain healthy leaf moisture without encouraging excess growth. Excess irrigation during the summer months can be very detrimental to native species that are used to dry summers.
2. Stay ahead of weeds by maintaining a regular schedule of hand pulling or weed whipping, before the seed heads mature, to reduce fire hazard and invasive seed banks.
3. Utilize mulch to suppress weeds.
4. Dry leaves and other debris that have collected in your rain gutters can be dangerous and ignite a fire very easily.



### Pruning for Healthy Plants During Fall

- Most plants will benefit from **occasional corrective pruning**, and all will benefit from the removal of dead wood. Time the pruning of individual plants over several years to allow them to recover — **try pruning about 1/3 of your plants in a given year, and no more than 20% of total plant volume, so that all are pruned at the end of three years.**
- Regularly remove dead material and branches from your trees and shrubs.
- Hand-prune inside branches to **reduce flush of growth**. Hedging and shearing alone results in weak, fast growth and more fuel.
- Prune Coast Live Oak trees in July–August, **during dormancy period**. It is best to prune when the dry weather is less likely to support pathogens that may attack the wounds. As much as possible, avoid pruning large limbs as this exposes the tree to possible infection and can take many years to recover. Avoid over-thinning interior branches, or **"lion tailing."**

### Things to Keep in Mind as You Do Your Maintenance

- Oak Tree Pruning or Removal: California oak tree trimming laws vary from city to city. Wider, taller and older oaks cannot legally be trimmed or felled without a permit throughout the state but check with local city or county administrators to find out how the law applies to oak trees in a specific location. Check the section on **Oak Woodlands of our website online for more information: [DefensibleSpace.org/plants](http://DefensibleSpace.org/plants)**
- Firewise Planting : Use low fuel volume, fire-wise plants. Visit our website for the section on **Plant Characteristics: [DefensibleSpace.org/plants](http://DefensibleSpace.org/plants)**



- Invasive Species : As part of their vegetation management activities, owners should not be planting invasive, and consider removing those that occur. For more information about invasive species, check out our website's section on [Invasive Species: DefensibleSpace.org/plants/#section-tab-invasive](https://DefensibleSpace.org/plants/#section-tab-invasive)



- Endangered Species and Migratory Birds: Restrictions exist that may impact when and where you may remove vegetation. Consult jurisdictional agencies, which may include National Park Service, State Parks, Mountains Recreation and Conservation Authority, California Department of Fish and Game, U.S. Fish and Wildlife Service. Whenever there is any doubt about clearing or thinning native brush, the US Fish and Wildlife Service and California Department of Fish and Wildlife should be consulted. We have more information on our website, visit the section on [Protected Species: DefensibleSpace.org/plants/#section-protected](https://DefensibleSpace.org/plants/#section-protected)

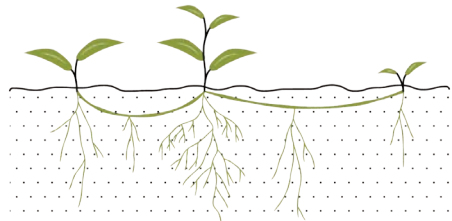

- Erosion: Excessive clearing can lead to erosion, causing slope destabilization. Please consult Forestry Division or Brush Clearance Unit prior to starting work.



- Streams: Restrictions impact activities near the bed, bank, and channel of a waterway. Consult the [Lake and Streambed Alteration Program of the California Department of Fish and Wildlife](https://wildlife.ca.gov/Conservation/Environmental-Review/LSA) for more information: [wildlife.ca.gov/Conservation/Environmental-Review/LSA](https://wildlife.ca.gov/Conservation/Environmental-Review/LSA)



- Lean & Planning: Late summer is a good time to begin planning for the fall planting season. Local botanical gardens or community colleges host design classes that will help you make the most of your garden. Visit [Plant Right](https://plantright.org) to find recommended alternatives to invasive plants: [plantright.org](https://plantright.org)

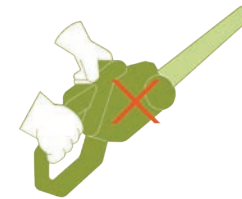

- Do Not Use Leaf Blowers: Leaf blowers are harmful to the environment both for noise and air pollution as well as for the balance of the wildlife ecosystem. Leaf blowers blow away mulch, topsoil decreasing your plants ability to regulate temperature and retain moisture. Leaf blowers are also a fire hazard due to the engine heat and the sparks they can generate. Use a rake instead.

# What Is A “Fire-Resistant” Plant?

Visit our site for more info:  
[DefensibleSpace.org/plants](https://DefensibleSpace.org/plants)

# Plants

## What Is a “Fire-Resistant” Plant?

Fire-resistant plants are those that do not readily ignite from a flame or other ignition sources. These plants can be damaged or even killed by fire; however, their foliage and stems do not significantly contribute to the fuel and fire’s intensity. **There are several other significant factors that influence the fire characteristics of plants**, including plant moisture content, age, total volume, dead material, and chemical content.

Plant lists can be misleading, giving the homeowner or landscape designer the impression that fire-safe landscaping is just about choosing the right species and avoiding the wrong ones. The reality is that landscape maintenance is essential, and any plants can burn under the right conditions. A well maintained, irrigated ‘flammable’ plant can represent a lower ignition risk than a neglected ‘firesafe’ plant. Because **any plant species can burn**, we focus instead on the underlying principles behind designing a fire-safe home and landscape, and on maintaining structures and plants properly.

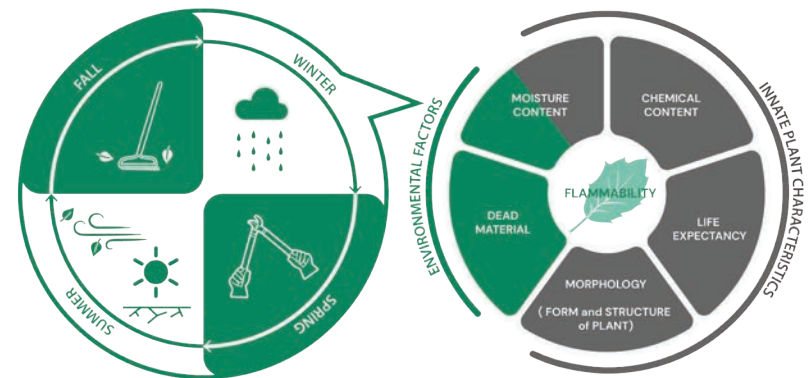

## Clearing up the Myth: Conditions over Species

Remember that the condition of the plant is often as important as its species. Many fire-hazardous plants can be relatively ignition-resistant **if properly maintained and irrigated, especially natives**. Depending on its growth form and access to water, the



same species may be ignition resistant in one environment and flammable in another. Water-stressed plants in poor condition are more likely to burn readily. Those species already identified as fire-hazardous may become explosively flammable when poorly maintained. South-facing slopes, windy areas, sites with poor soils and urban landscapes are more stressful for plants and often lead to greater hazard from burning vegetation.

### The Characteristics of Fire-Hazardous Plants

Learn to identify fire-hazardous plants by their characteristics, structure, and maintenance! This is not an exhaustive list, and some plants not listed here may present a fire hazard when drought stressed or poorly maintained. Any plant in poor health, lacking irrigation, or with a buildup of dry or dead material may burn. Most common fire-hazardous plants typically share certain characteristics as below:

- Plants that are **summer-dormant** unless being watered year-round (e.g., sagebrush, sages, etc.).
- Plants that **produce dry leaf-litter and duff** that accumulates atop the soil and on other plants in the vicinity.
- Trees and shrubs with **dry, peeling bark**.
- Trees and shrubs that retain **clusters of dead leaves/branches/fronds** (e.g., palms, eucalyptus, Italian cypress).
- **Dry grasses** that grow green in the winter and turn yellow/brown in the summer.

### Plant Characteristics & Maintenance Steps to Reduce Ignition Risk

- **There are no “fire-proof” plants.**
- Plants that are regularly watered, reducing dead leaves/duff production.

- Large, green trees and shrubs maintained without dead branches and clusters of dead leaves (e.g., coast live oaks that can act as a shield against flying embers).
- Plants with high moisture content and easily bent leaves.
- Plants with sap that looks more like water.
- Plants with thick leaves.
- Plants without fragrance.
- Plants with silver or gray leaves.
- Plant leaves without hair.



# The Habitat Value of A Native Garden

# Plants

Visit our site for more info:  
[DefensibleSpace.org/plants](https://DefensibleSpace.org/plants)

## Using Native Plants: Many Benefits!

Native plants are **essential ecosystem components** and provide habitat for native birds, butterflies and other wildlife. California's floristic province is known as a global hotspot for its diversity of unique plants and animals. To preserve our natural heritage, it is important to live responsibly in the Wildland-Urban Interface.



Good fire preparation in your landscape can help protect wildlands from damage, but sustainable and firewise gardens also conserve water, limit the use of potentially harmful chemicals such as fertilizers and pesticides, and avoid invasive plant species.

Many native (and CA friendly) plants grow slowly and maintain high levels of moisture in their leaves and stems with little irrigation. By choosing these plants, you can **protect the health of neighboring habitat and create a beautiful lower maintenance garden.** Some benefits of native plants:

- Save Water: Once established, many California native plants need **minimal irrigation** beyond normal rainfall.
- Lower Maintenance: While no landscape is maintenance free, California native plants require **significantly less time and resources** than common non-native garden plants.



- Pesticide Freedom: Native plants have developed their own defenses against many pests and diseases. Since most pesticides kill indiscriminately, **beneficial insects become secondary targets in the fight against pests.**
- Wildlife Viewing: Native plants, hummingbirds, butterflies, bees, and other beneficial insects are "made for each other." Research shows that native wildlife clearly prefers native plants.

- Support Local Ecology: As development replaces natural habitats, planting gardens, parks, and roadsides with California native plants can help provide an important “bridge” to nearby remaining wildlands.

Get involved in your community and with local land-use planning processes to help preserve our California native plants and wildlife!



### Looking for Examples? Here Are Some Fire-Resistant Native Plants for You!

Some of our favorite California natives also present some fire-resistant characteristics. Here is a partial list you might want to consider. The full list is available on our website: [Defensiblespace.org/plants](https://www.defensiblespace.org/plants)

**Important Note: All plants will eventually burn.** There is no such thing as a fireproof plant. There are some plants that can retain moisture, even in dry areas, and are called fire resistant. This list is designed to identify some Californian native plants that are fire resistant and have wildlife value. The purpose of this list is to help place fire-resistant and wildlife important plants in areas where brush clearance can leave an area barren.

Photos of the plants listed are courtesy of the Theodore Payne Foundation, Tree of Life Nursery, and Elisa Read Pappaterra.

#### Trees



##### Toyon

*Heteromeles arbutifolia*

A classic California native, it has white flowers in the summer and berries in the winter, it gets good marks from Los Angeles, Orange, San Diego and the Inland Empire.



##### Coast Live Oak

*Quercus agrifolia*

Handsome shade tree. Round-headed with dense foliage, grows 20 to 70 feet tall. Smooth, dark grey bark, with leathery dark green leaves. Native to coastal central and Southern California.

#### Shrubs



##### Lemonade Berry

*Rhus integrifolia*

A very drought-resistant shrub that provides cover and food to wildlife. California Thrasher uses its fruits and leaf material for nesting. It also is an excellent erosion control plant.



##### Guadalupe Island Rock Daisy

*Perityle incana*

Dependable plant with attractive silver foliage that contrasts beautifully with darker foliage of Ceanothus and Rhamnus. Panicles of bright yellow flowers shroud the plant in spring. Recommended for butterfly gardens.

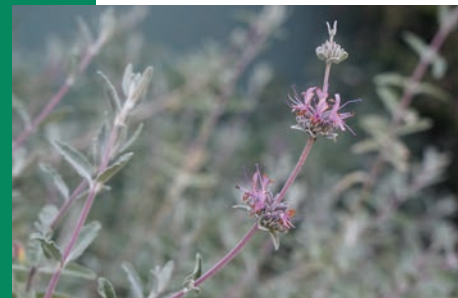

##### Sages

*Salvia sp.*

Nothing evokes California quite like a sage-scented hillside! Salvias are scented due to natural oils, and in



nature these oils can be flammable. But sages are an exception to the avoid planting rule, because if you **keep them clean and tidy and lightly irrigate them every two weeks**, it significantly reduces their flammability. This is a good example of how maintenance is key to reducing fire risk and improving habitat quality.

## Groundcovers



**Dwarf Coyote Bush**  
*Baccharis pilularis* "Pigeon Point"

While not a very "showy" plant, it does produce some flowers and has a deep root system, that provides good erosion control. It grows 12 to 18 inch in height. It adds cover and seeds for a variety of birds. (LA County Fire approved)



**Willow Coyote Mint**  
*Monardella linoidea viminea*

This federally protected coyote mint grows up to 18 inch tall and prefers North facing (somewhat shaded) or riparian areas. It has a long blooming cycle, flowering through the summer and fall and is an attractant to hummingbirds and butterflies. Songbirds also eat the seeds.

# Fire & Invasive Species

Visit our site for more info:

[DefensibleSpace.org/plants](https://DefensibleSpace.org/plants)

# Plants



## Invasive Plants Can Increase Fire Hazard

Invasive plants, the **non-native species that cause ecological or economic harm**, are one of the great threats to the health of Southern California's Wildland-Urban Interface (WUI) areas. Fire and plant invasions are related in several ways. In natural plant communities, **the presence of invasive plants can increase the risk of wildfire**. For example, invasive plants like giant reed (*Arundo donax*) can produce a great deal of biomass and then become dormant and dry, thus increasing the intensity and severity of fire, especially in riparian areas where fires are naturally rare and low intensity.



Invasive Black Mustard (*Brassica negra*) ©Bob Frederick

## Invasive Plants Can Harm the Wildland Health

Most plants do not escape our yards and gardens, but the handful that do can cause serious problems. Animals, wind, and water move plants and seeds far from where they were planted. Once established in natural areas, **these plants displace native vegetation and greatly reduce wildlife diversity**. Invasive plants also fuel wildfires, contribute to soil erosion, clog streams and rivers, and increase flooding. Poor maintenance of cleared areas can promote their

spread. Because they thrive in disturbed soils, **improper clearance or over-clearance often leads to a landscape dominated by invasive plants**. These plants can produce more fuels than native vegetation, increasing the potential for ignition.

## How to Recognize Invasive Species?

When choosing plants for your fire-safe landscape, you can help protect the health of neighboring wildlands by avoiding invasive species. You can find **a full list of invasive species developed by the California Invasive Plant Council ([cal-ipc.org/plants/profiles](http://cal-ipc.org/plants/profiles))**. Remember when buying plants to make sure to check the scientific name so that you are getting the species you want!

We created below **a list of the most common invasive species in southern California**. This list is non-exhaustive, and we encourage you to **consult [DefensibleSpace.org/plants](http://DefensibleSpace.org/plants) for the full list and additional information**. Photos of the plants listed are courtesy of Elisa Read Pappaterra, Santa Monica Mountains National Recreation Area, Argo Navis, Sleddog116 at English Wikipedia, Luis Fernández García, and Cal-IPC Joseph DiTomaso.



Giant Reed  
*Arundo donax*

This grass grows along streamsides, where it can reach over 20 feet tall. It grows in dense thickets that clog waterways and is a fire hazard. When clumps of arundo are washed downstream during storms, they become trapped against bridges and create a maintenance problem where they land. Arundo creates less shade than the native trees it replaces, increasing water temperatures to a level that is dangerous for native fish.





### **Black Mustard**

*Brassica nigra*

Is a winter annual herbaceous shrub. It grows profusely and produces allelopathic chemicals that prevent germination of native plants. The spread of black mustard can increase the frequency of fires in chaparral and coastal sage scrub, changing these habitats to annual grassland.

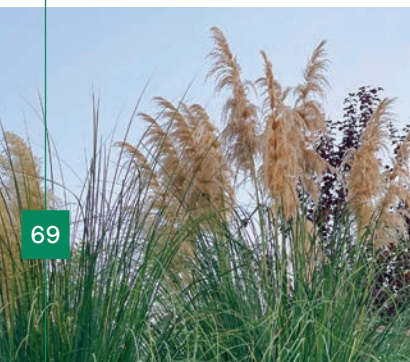

### **Pampasgrass / Jubatagrass**

*Cortaderia sp.*

Wind can carry the tiny seeds of these plants up to 20 miles. The massive size with its accumulated litter reduces wildlife habitat, limits recreational opportunities in conservation areas, and creates a fire hazard.



### **Canary Island & Mexican Fan Palms**

*Phoenix canariensis,*  
*Washingtonia robusta*

Most palms are good garden plants, but Mexican fan palm and Canary Island date palm are extremely invasive. In Southern California, they invade wetland areas, crowding out native vegetation. Canary Island date palm seeds are spread by birds. Dense groups of palms with untrimmed fronds harbor rats and snakes and can be a fire hazard.



### **Periwinkle**

*Vinca major*

This aggressive grower has trailing stems that root wherever they touch the soil. Their ability to resprout from stem fragments enables periwinkle to spread rapidly in shady creeks and drainages, smothering the native plant community. accumulated litter reduces wildlife habitat, limits recreational opportunities in conservation areas, and creates a fire hazard.



### **Fountain Grass**

*Pennisetum setaceum*

Spreads aggressively by seed into natural areas by wind, water, or vehicles. Fast grower; impedes the growth of locally native plant species and eventually takes over natural areas. They also raises fuel loads and fire frequency in natural areas.



### **False Sandalwood**

*Myoporum laetum*

Invades along the coast from Sonoma County to San Diego. Forms dense stands with no other vegetation. Can cover large areas. Spread by birds. Leaves and fruits are toxic to wildlife and livestock. Burns easily.





**Russian Olive**  
*Elaeagnus angustifolia*

Found throughout California, Russian Olive are able to spread long distances with the help of birds and mammals. Invades river and stream corridors, pushing out native willows and cottonwoods. Reduces water levels. Provides poor wildlife habitat. Serious invader in other western states.



**English Ivy**  
*Hedera helix*

Some ivy species in the Hedera genus are a big problem in California. They can smother understory vegetation, kill trees, and harbor non-native rats and snails.



**Tree of Heaven**  
*Ailanthus altissima*

Although not commonly sold in nurseries, this tree is sometimes “shared” among gardeners. Tree-of-heaven produces abundant root sprouts that create dense thickets and displace native vegetation. These root sprouts can be produced as far as 50 feet away from the parent tree. In California, it is most abundant along the coast and Sierra foothills, as well as along streams. A single tree can produce up to a million seeds per year.



**Brooms**  
*Genista monosperma* &  
*monspessulana*, *Cytisus striatus*  
& *scoparius*, *Spartium junceum*

Brooms have invaded over one million acres in California. The flowers produce thousands of seeds that build up in the soil over time, creating dense thickets that obliterate entire plant and animal communities. Grows quickly, creating a fire hazard in residential landscapes.



**Pepper Trees**  
*Schinus spp*

Despite the fact that Peruvian peppertree is often called California peppertree, Pepper Trees are native to South America. Seeds are transported by birds and mammals into natural areas. The aggressive growth of peppers enables them to displace native trees and form dense thickets in natural areas. It has been a serious problem in southern California.



**Highway Iceplant**  
*Carpobrotus edulis*

This vigorous groundcover plant forms impenetrable mats that can compete directly with native vegetation, including several rare and threatened plants.

# No Two Places Alike: Learn About Your Location

Use our interactive geographic information system (GIS) map to learn about the individual qualities of your location. Our GIS map will help you understand how your property fits within different local habitat types, for example, Oak Woodland, Coastal Sage Scrub, or Chaparral. You can explore past fires in your area, as well as the jurisdiction and protection plans established in your community.

We hope this information helps you understand your particular location, and how the decisions you make on your own property – and together as a community – can influence your vulnerability to wildfire. Go online and use this interactive map now:

[DefensibleSpace.org/location](https://DefensibleSpace.org/location)



# Location



## Organize with Your Neighbors: Community Planning

75

Visit our site for more info:  
[DefensibleSpace.org/community](https://DefensibleSpace.org/community)

# Community

Community Planning is key to reducing vulnerability to wildfires. Your defensible space may overlap with your neighbors' properties -- you may find that your home ignition zone (the first 100 feet of your home) overlaps into neighboring properties or vice-versa for your neighbors. To maximize the benefits of your work, it is extremely important to work collaboratively with your neighbors to understand the nature of your shared risks and to work together to reduce those risks.

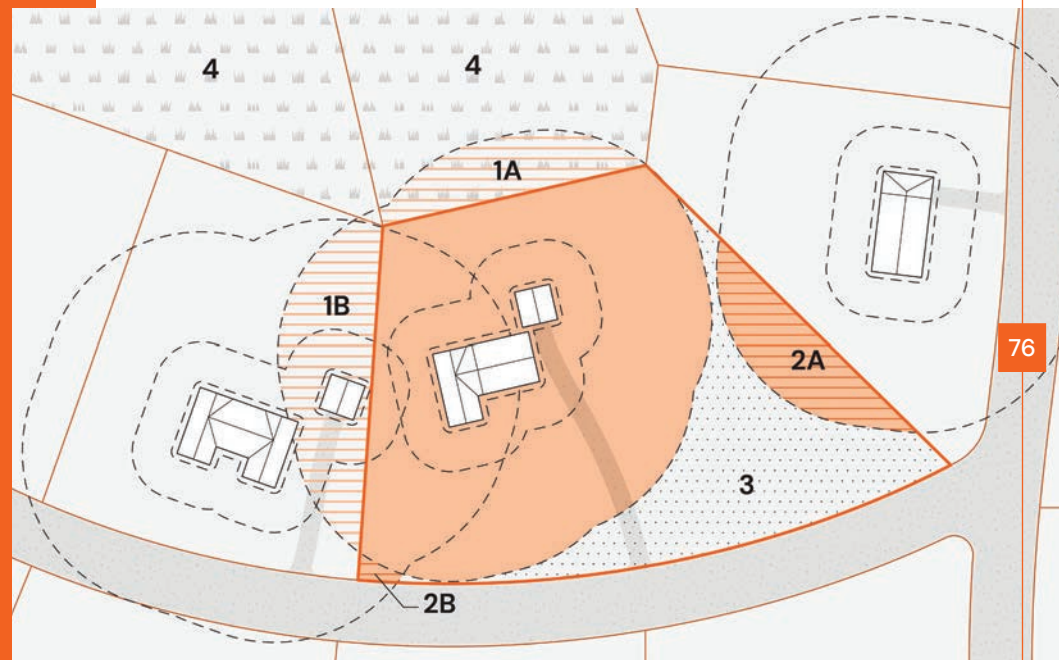

76

### Your Defensible Space Starts from Your Home



Your home itself is the greatest source of potential threat to your neighbors if it ignites. The heat and embers from a structure fire are greater than any vegetation area of similar size. Protect your home from ignition to help protect your community.



Property Line



The defensible space on your property

### Your Defensible Space Extends into Neighboring Properties

**1A** The outermost part of your thinning zone extends onto your neighbor's undeveloped property with native coastal sage or chaparral. Consider fire mitigation measures. You can also ask permission of the property owner and use minimum impact thinning techniques.

**1B** The outermost part of your thinning zone occurs across your neighbor's ember-resistant, intermediate, and thinning zones. Your neighbors' work to protect their own home will provide similar protection to your home.

### A Neighbor's Defensible Space Extends onto Your Property

**2A** The outermost thinning zone for your neighbor's home falls outside of your own defensible space zone. This requires cooperation between neighbors and depends on the property owner's goals for their landscape and the risk posed by the vegetation. Options available include a deflection wall, vegetable garden or orchard, irrigated native landscaping and minimum-impact thinning techniques.

**2B** A small area of your neighbor's thinning zone falls next to, but outside of your own thinning zone. It would make sense to treat this area in the same manner as your own. In some jurisdictions you may be responsible for maintaining a defensible space for your neighbor's benefit.

### Undeveloped Neighboring Parcels

**3** On parcels of land that extend beyond 100' from the dwelling, the type of vegetation, terrain, and local regulations may require additional thinning beyond 100 feet. The Los Angeles County Fire Department may require up to 200' of defensible space. Get in touch with your local Fire and Planning Departments

before modifying any native vegetation more than 100 feet from the home.

**Native vegetation is often protected by regulations, so do not remove previously unmodified habitat without first contacting your local planning department for specific limitations and processes.**

### Parcels of Land Larger than the 100 Feet Sustainable Defensible Space Zone

**4** Undeveloped parcels with native habitat should be conserved wherever practicable to maintain ecosystem services such as slope stabilization, water filtration, biodiversity, and wildlife habitat.

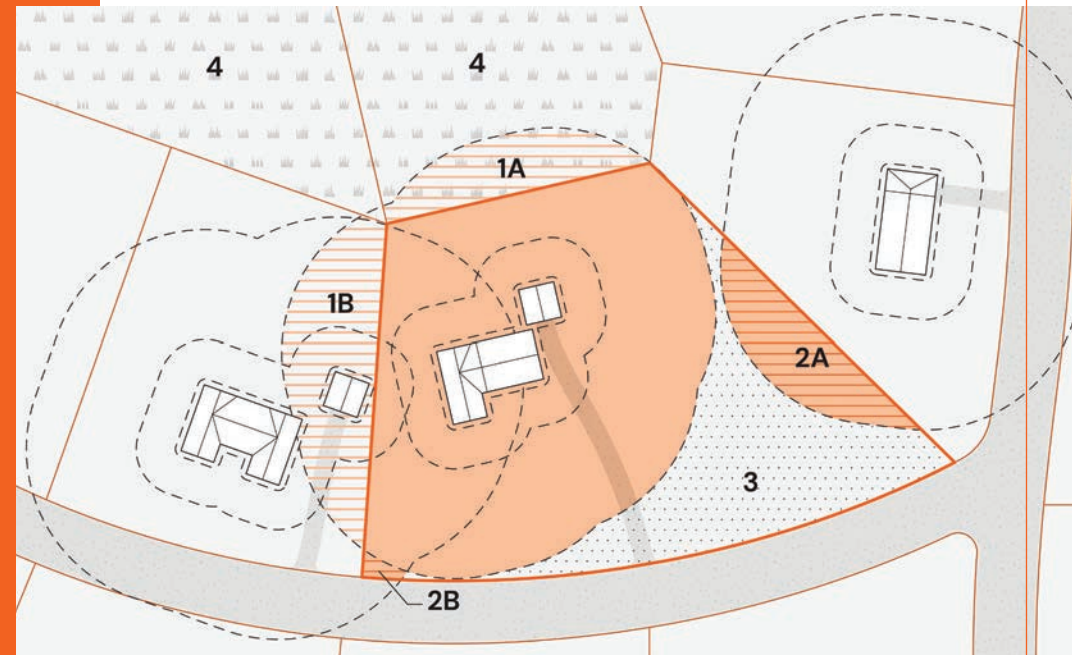



## What to Do Before, During, & After a Fire

Visit our site for more info:

[DefensibleSpace.org/community](https://DefensibleSpace.org/community)

# Community

Creating and maintaining a sustainable defensible space is an important step in increasing wildfire safety at the individual property scale. However, the risk to a community is based on the most vulnerable properties which is why it most effective to carry out vegetation management and home hardening activities across a neighborhood to address the whole 'fireshed'. This cooperation within a community and/or region is key to reducing wildfire risk, and also has a larger positive impact on local ecosystems if all community members follow the guidelines supporting native plants and wildlife.

### Sign up Today for Emergency Alerts

We **strongly recommend** subscribing to the following emergency notification systems:

- All local agencies — Nixle  
Text your zip code to 888777 to opt-in or sign up online to receive emails, texts or voice messages with alerts and advisories from local law enforcement. This will sign you up to receive alerts from all agencies using Nixle in your zip code. You can also go online: [local.nixle.com/register](https://local.nixle.com/register)
- City of Los Angeles — NotifyLA:  
[emergency.lacity.org/alerts/notifyla](https://emergency.lacity.org/alerts/notifyla)
- Los Angeles County — Alert LA County:  
[lacounty.gov/emergency/alert-la](https://lacounty.gov/emergency/alert-la)
- Ventura County — VC Alert Emergency Notification System:  
[readyventuracounty.org/vc-alert/](https://readyventuracounty.org/vc-alert/)

### Before the Fire

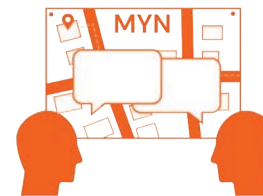

Communities can work together to become more fire adapted by working with Fire Safe Councils, adopting Firewise standards and/or becoming a Fire Adapted Community, and working

with local agencies to do **Community Wildfire Protection Planning**.

Here are some options for you:

Create a **Map Your Neighborhood** (MYN) group at [mil.wa.gov/map-your-neighborhood](https://mil.wa.gov/map-your-neighborhood). MYN is a free program designed by the Washington Emergency Management Department and implemented locally by the American Red Cross Los Angeles Region, to improve readiness at the neighborhood level. MYN teaches neighbors to rely on each other. It takes just ONE person to begin. The Map Your Neighborhood program guides you and your neighbors through **simple steps to help enhance your preparedness for an emergency**. These steps will help you to quickly and safely take actions that can minimize damage and protect lives. It is designed to improve disaster readiness at the neighborhood level, which means about 15 to 20 homes or a defined area that you can canvas in 1 hour. It teaches neighbors to rely on each other during the hours or days before emergency or utility responders arrive.

The City of Los Angeles re-imagined the program and created **Ready Your LA Neighborhood** (RYLAN) at: [readyla.org](https://readyla.org)

### During the Fire

While a fire is burning, the primary response will be made by the local, state, and federal agencies tasked with emergency response, including local fire departments, CalFire, Forest Service, or Bureau of Land Management depending on land ownership in the burn area. The following community organizations are also commonly involved with disaster response:



- Community Emergency Response Teams:  
[cert-la.com](https://cert-la.com)
- American Red Cross' local chapters:  
[redcross.org/find-your-local-chapter.html](https://redcross.org/find-your-local-chapter.html)
- Volunteers from your local organizations (e.g. Topanga Coalition for Emergency Preparedness):  
[t-cep.org](https://t-cep.org)

### After the Fire



Recovery strategies vary depending on the damages caused by wildfire. Again, **working together** to address these damages and values at risk is more effective than going it alone. Most damage beyond the home occurs on a landscape scale too large for a single person to tackle on their own. We strongly encourage you to work with your community to protect your land after a fire.

- **Structure Loss:** When structures have been lost, structure debris must be removed before rebuilding. This is usually coordinated between the insurance provider and the local jurisdiction. When large numbers of homes are lost, this debris-clearing and rebuilding process is often done by state and local agencies on a neighborhood basis.
- **Erosion Risk:** Often after a wildfire, vegetation is consumed, leaving bare ground vulnerable to erosion. Action may be needed to reduce post-fire erosion risk. Working together with local agencies, such as the local Resource Conservation District can reduce risk for all.
- **Neighborhood Landscape Loss:** Working together with neighbors to re-establish a fire resistant and water your efficient landscape can lead to a safer and more aesthetically pleasing neighborhood.
- **Working Landscape Loss:** Managed agricultural, forest and range lands affected by fire can be restored by owners through individual efforts, or it may be possible to work with a local Resource Conservation District to take recovery actions together.

# Make Your “Wildfire Action Plan” Today!

# Community

Visit our site for more info:  
[DefensibleSpace.org/community](https://DefensibleSpace.org/community)

Now that you have done everything you can to protect your home, it is time to prepare your family. Your Wildfire Action Plan must be prepared with all members of your household well in advance of a wildfire. Each family’s plan will be different, depending on their situation. Once you finish your plan, practice it regularly with your family, and post it in a safe and accessible place for quick implementation. CALFIRE includes information about how to create a Wildfire Action Plan in its “Ready, Set, Go!” program.



## Ready, Set, Go!

The geography, weather patterns, and number of Wildland Urban Interface communities in California make this state particularly threatened by devastating wildfire. As catastrophic wildfires continue to increase each year in California, make sure to protect yourself and your family – plan, prepare, and stay aware. Property owners and residents in areas most at risk are encouraged to take the steps in CAL FIRE “Ready, Set, Go!” ([readyforwildfire.org/prepare-for-wildfire/ready-set-go](https://readyforwildfire.org/prepare-for-wildfire/ready-set-go)) to be ready for wildfire.

Get prepared for wildfire before it strikes by following **Ready, Set, Go!**

- **Be Ready!** Create and maintain defensible space and harden your home against flying embers.
- **Get Set!** Prepare your family and home ahead of time for the possibility of having to evacuate. Ensure you have a plan of what to take and where to go – evacuation plans may need specific requirements and adaptation due to COVID-19.
- **Be Ready to Go!** When wildfire strikes, go early for your safety. Take the evacuation steps necessary to give your family and home the best chances of surviving a wildfire.

## How to Create Your Wildfire Action Plan

Your Wildfire Action Plan must be prepared and familiar to all members of your household well in advance of a wildfire. Use the checklist below to help create your plan. Each family's plan will be different, depending on a variety of issues, needs, and situations.

Create an evacuation plan that includes:



A **designated emergency meeting location** outside the fire or hazard area. This is critical to determine who has safely evacuated from the affected area.

Several different **escape routes** from your home and community. Practice these often so everyone in your family is familiar in case of an emergency.



An **evacuation plan for pets** and large animals such as horses and other livestock.

A **Family Communication Plan** that designates an out-of-area friend or relative as a point of contact to act as a single source of communication among family members in case of separation.



### Be Prepared

- Have fire extinguishers on hand and train your family how to use them (check expiration dates regularly).
- Ensure that your family knows where your gas, electric, and water main shut-off controls are located and how to safely shut them down in an emergency.
- Assemble an Emergency Supply Kit for each person; this is recommended by the American Red Cross.
- Maintain a list of emergency contact numbers posted near your phone and in your emergency supply kit.
- Keep an extra Emergency Supply Kit in your car, in case you cannot get to your home due to fire or another emergency.

- Have a portable radio or scanner so you can stay updated.
- Tell your neighbors about Ready, Set, Go! your Wildfire Action Plan and Defensiblespace.org.

### 6 P's: Include These 6P's in Your Wildfire Plan & Keep Them Ready in Case Immediate Evacuation Is Required



#### People & Pets



#### Papers, Phone Numbers, & Important Documents



#### Prescriptions & Eyeglasses



#### Pictures & Irreplaceable Memorabilia



#### Personal Computer, Hard drive, & Disks



#### Plastic (Credit Cards, ATM Cards), & Cash

## Self-Assessment Checklist

87

Visit our site for more info:

[DefensibleSpace.org](https://DefensibleSpace.org)

# Tools for House & Landscape

### ROOFING

- Remove vegetation debris from your roof, and inspect vulnerable areas regularly, such as valley, dormer, and roof-to-wall intersections.
- Remove tree limbs that overhang the roof to create at least 5 feet clearance.
- Check for gaps between roof covering and sheathing (bird-stopping).
- Cover chimney and stovepipe outlets with spark arrestor.
- Make sure tree branches are at least 10 feet away from any chimney outlet.

### OPEN-EAVE

- Evaluate the fire-resistance of existing soffits and replace soffits that are not fire-resistant.
- Remove any debris and combustible material (e.g., plants, patio furniture, vegetation debris, firewood, etc.) from under eaves and overhangs.

### RAIN GUTTERS

- Check that leaf-guards are correctly installed and not dislodged.
- Replace heat-distorted gutters, leaf-guards, and downspouts.
- Check and remove vegetation debris regularly.

### VENTS

- Install non-corrosive metal mesh screens with a maximum opening of 1/8 inch .
- Baffle attic and soffit vents.

88

- Remove vegetation near vent openings.
- Do not store combustible items such as cardboard boxes and construction materials near vent openings or within the 5-foot zone around the house.

### WINDOWS & SKYLIGHTS

- Replace windows with multi-pane options including tempered glass.
- Install screens in all operable windows to limit ember intrusion in case of window failure.
- Close all windows and skylights during wildfire threats.
- Remove vegetation debris that accumulates around the skylights.
- Move patio furniture and potted plants away from the windows and sliding doors during wildfire threats.

### DOORS & GARAGES

- Remove doormats on red flag warning days.
- Remove vegetation and other combustible materials that are within 5 feet of windows and doors.
- Make sure the space between the garage door and framing is well sealed. Install weatherstripping if needed.

### WALLS, SIDINGS, & COATINGS

- Do not store any combustible items (e.g., cardboard boxes, firewood, etc.) near the sidings.
- Remove vegetation debris, like leaf litter and pine needles from the base of the siding.

- Create an ember-resistant zone (see pages 31-34) to minimize the ignition risk.

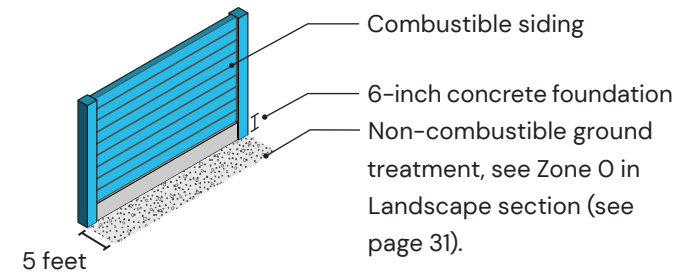

### FENCES

- Replace the 5 feet of fencing connecting to a building with noncombustible material.
- Keep the area at the base of the fence clear of vegetation debris such as pine needles and leaf litter.
- Regularly maintain the physical condition of the fence and the landscape vegetation planted along your fence.
- Do not store firewood along your fence.

### DECKS

- Do not store combustible material beneath the deck.
- Create an ember-resistant zone by removing vegetation under and within 5 feet of the deck.
- Routinely remove debris that accumulates in-between deck board gaps, and at the intersection between the deck and the house.
- Apply metal flashing or foil-face bitumen tape on top of and a few inches down the side of the support joists. This will minimize fire growth in case of ember-ignition (not effective against direct flame contact).



## DEFENSIBLE SPACE

### Zone 0: Ember-Resistant Zone (0–5 Feet)

- Replace organic mulch with a non-combustible alternative.
- Keep the surrounding area of the house clear of combustible materials.
- Limit plants in this area to low growing, nonwoody, properly watered and maintained plants.
- Remove all dead and dying weeds, grass, plants, shrubs, trees, branches, and other vegetative debris.
- Include the footprint of any deck or attached structure within this zone.

### Zone 1: Home Protection Zone (Extends 30 Feet Outwards, 50 Feet on Slopes)

- Plan your landscape as vegetation “islands” surrounded by hardscape features (such as paving and walls).
- Keep the vegetation lean, green, and well irrigated.
- Remove all dead plants and grasses.

### Zone 2: The Thinning Zone (Extends 100 Feet Outwards)

- Consider native plants for slope stabilization (see page 42).

### Common to Zone 1 & Zone 2

- Maintain proper horizontal and vertical spacing between plants, and inspect vegetation to remove ladder fuels (see pages 68–72).
- Plant primarily native plants to support local ecosystems.
- Remove invasive species, especially annual dry grasses.
- Maintain your landscape following seasonal maintenance recommendations (see pages 49–56).

We Have More:  
Check out the FAQ  
& Resources on  
Our Website!

Visit our site for more info:

[DefensibleSpace.org/FAQ](https://DefensibleSpace.org/FAQ)

[DefensibleSpace.org/resources](https://DefensibleSpace.org/resources)

More?

# Thank you for reading!

# Please share this info with friends and neighbors.

RCDSMM Thanks  
All of Our Partners

## Funding Sources



## Technical Advisory Committee



TreePeople

Content Creation, Brand, and Brochure

# RIOS

The 2020 California wildfire season has caused historic loss of life, property, and wildlands. Southern California is one of the most fire-prone environments in the world and has more homes and area burned per decade than any other region in the United States.

Wildfires are a natural part of the ecosystem, and it is of utmost importance that we prepare our properties for this threat. Sustainable Defensible Space is here to help keep our homes, communities and wildlands safe and vibrant. For more information, scan the QR code inside the cover or visit:

[DefensibleSpace.org](https://DefensibleSpace.org)

# Introduction HomeLand scapePlants LocationCom munityFAQ Resources